

KL-260T FTTx Fusion Splicer

30 Years of Craftsmanship in Manufacturing

NEW GENERATION

Middle Trunk Line Fusion Splicer

■ Core features

- 3D Surrounds Dual Heating Element
- Design of Tool free Disassembly Integrated SOC Fixture
- Tool free Hot Swappable OPM/VFL module



**Splicer No.1
pioneer di china
33 tahun**



KL-260T FTTx Fusion Splicer

30 Years of Craftsmanship in Manufacturing

NEW GENERATION

Middle Trunk Line Fusion Splicer

■ Specification

Splice Method :	Active Clad-Alignment
Applicable Fibers :	SM(ITU-T G.652&G.657) / MM(ITU-T G.651) / DS(ITU-T G.653) / NZDS(ITU-T G.655)
Compatible Fiber/Cable :	0.25~3.0 mm / indoor flat cable
Fiber Holder :	Replaceable
Fiber Diameter :	Cladding: 80-150µm, Coating: 100~1000µm
Fiber Cleave Length :	8~16 mm
Splice mode :	Max 128 modes
Typical Splice Loss :	SM: 0.02dB / MM: 0.01dB / DS: 0.04dB / NZDS: 0.04dB / G.657: 0.02dB ★Ⓞ
Return Loss :	>>60dB
Splicing Time :	SM Quick mode : 8 sec
Estimated Splice Loss :	Available
Heating Time :	Quick mode 8 sec.(SM G652 250µm 40mm Sleeve) adjustable
Protection Sleeve Length :	20mm, 30mm, 40mm, 50mm, 60mm
Heat Programs:	Max 32 modes
Battery :	5200mAh Battery Capacity, Typical 300 Cycles (Splice&Heat) per Charge ★Ⓞ
Electrode Life :	5000 arcs, can be extended by using an electrode grinder ★Ⓞ
Auto-start :	Splice / Heating
Automatic Fiber Identification :	/
Automatic ARC Identification :	Automatic arc calibration by air pressure and temperature
Results Storage :	The last 10,000 splice records and 2,000 result images
Tension Test :	1.96~2.25N
Operating Condition :	Altitude: 0~5000m, 0~95% relative humidity, -20~50°C, Max Wind 15m/s
Storage Condition :	0~95% relative humidity, -20~60°C
Display :	4.3" Touch Screen
Fiber Magnification :	X, Y, XY, X/Y : 320X Magnification
Power Supply :	AC Input 100-240V, DC Input 9-14V
Terminal :	USB2.0
Weight :	1.65kg without battery / 1.92kg with battery
Size :	136.8H x 137W x 136.5D mm (including rubber bumper)
★Ⓞ With identical fibres(in room temperature). Measured by cut-back method relevant to ITU-T and IEC standards.	
★Ⓞ Splice & Heat cycles based on 40mm shrink tube/0.25mm fiber,may vary depending on the battery status and operating environment.	
★Ⓞ Electrode life may vary depending on the operating environment.	

KL-260T FTTx Fusion Splicer

30 Years of Craftsmanship in Manufacturing
NEW GENERATION
Middle Trunk Line Fusion Splicer



260T FTTx Fusion Splicer

- 3D Surrounds Dual Heating Element
- Design of Tool free Disassembly Integrated SOC Fixture
- Tool free Hot Swappable OPM/VFL module

Al-Metal Material

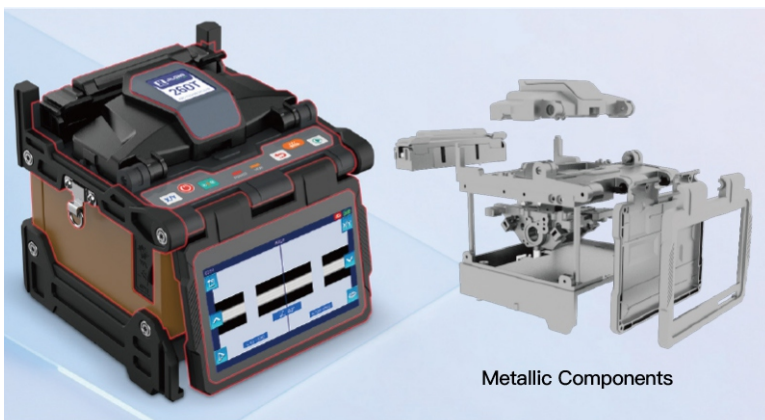

3D Surrounds Dual Heating Element Design

10-Second Rapid Heating (Fast Mode)

Real core alignment

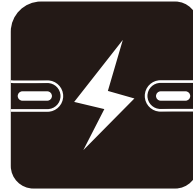
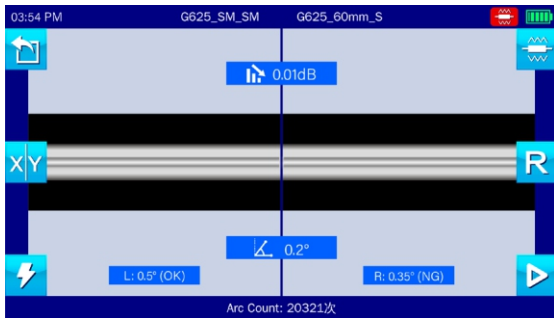

Fast-splicing 8s



Fast-heating 18s

6800mAh

High capacity Li-battery



6800mAh capacity battery



300 splices & shrinks per charge

4.3-Inch capacitive touch screen

Newly upgraded touch screen, easy to operate, and more user-friendly UI interface.



New UI interface design

Upgraded interface and more user-friendly interaction

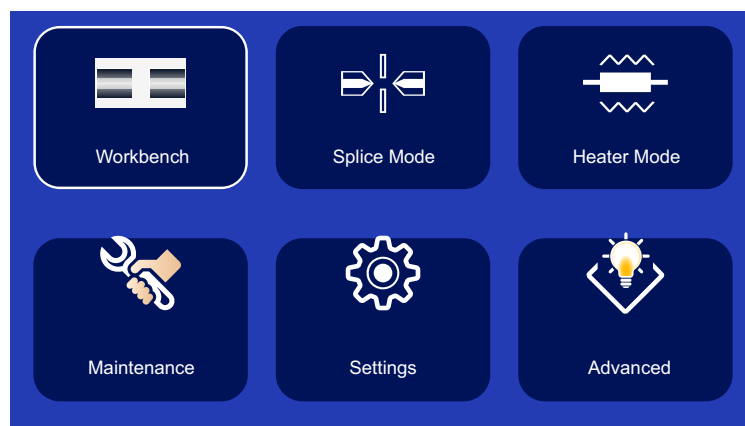
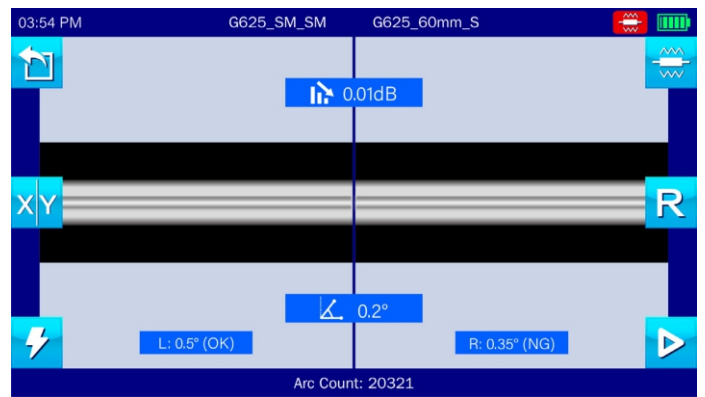
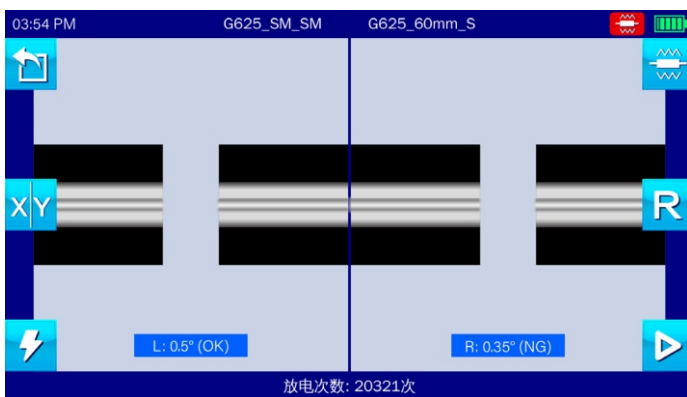

KL-260T FTTx Fusion Splicer

30 Years of Craftsmanship in Manufacturing

NEW GENERATION

Middle Trunk Line Fusion Splicer

High Expansibility fiber optic cleaver operating platform design



Suitable for different
models fiber optic cleavers

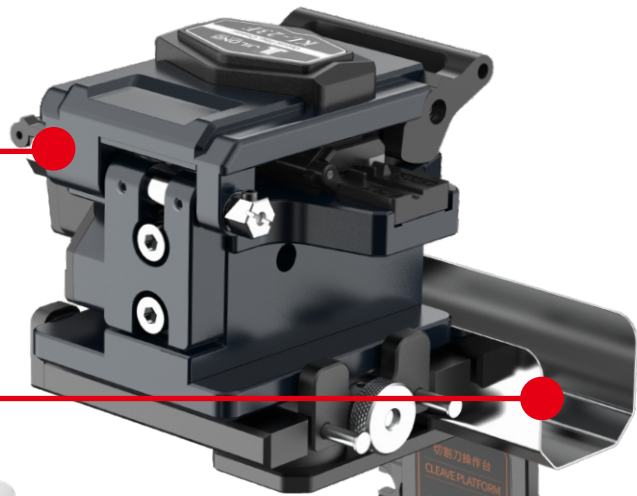

Cooling tray can be placed

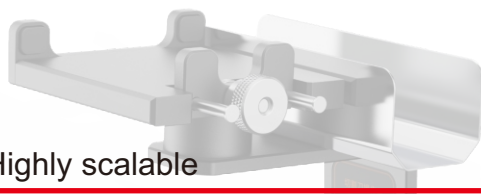

Highly scalable

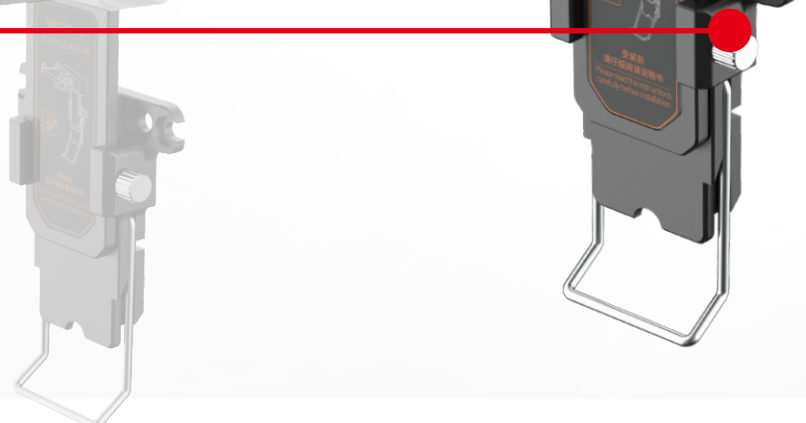

KL-260T FTTx Fusion Splicer

30 Years of Craftsmanship in Manufacturing

NEW GENERATION

Middle Trunk Line Fusion Splicer

■ Specification

Splice Method	Core Alignment
Applicable Fibers	SM(ITU-T G.652&G.657) / MM(ITU-T G.651) / DS(ITU-T G.653) / NZDS(ITU-T G.655)
Compatible Fiber/ Cable	0.25~3.0 mm / Rubber-insulated fiber cable
Fiber Holder	Replaceable universal fiber holder
Fiber Diameter	Cladding:80-150µm, Coating: 100-1000µm
Fiber Cleave Length	8~16 mm
Splice Mode	Max 128 modes
Typical Splice Loss	SM: 0.02dB / MM: 0.01dB / DS: 0.04dB / NZDS: 0.04dB / G.657: 0.02dB ★①
Return Loss	>>60dB
Splicing Time	SM Quick mode: 8 sec/ SM Average: 15 sec
Estimated Splice Loss	Available
Heating Time	Quick mode 18 sec.(SM G652 250µm 40mm Sleeve) adjustable★②
Protection Sleeve Length	20mm,30mm,40mm,50mm,60mm
Heat Programs	Max 32 modes
Battery Capacity	6800mAh Battery Capacity, Typical 300 Cycles (Splice&Heat) per Charge ★③
Electrode Life	5000 arcs, can be extended by using an electrode grinder ★④
Auto-start	Splice / Heating
Automatic Fiber Identification	/
Automatic ARC Identification	Automatic arc calibration by air pressure and temperature
Results Storage	The last 10,000 splice records and 2,000 result images
Tension Test	1.96~2.25N
Operating Condition	Altitude: 0~5000m, 0~95% relative humidity, -20~50°C, Max Wind 15m/s
Storage Condition	0~95% relative humidity, -20~60°C
Display	4.3-Inch capacitive touch screen
Fiber Magnification	X, Y, XY, X/Y : 320X Magnification
Power Supply	AC Input 100-240V, DC Input 9-14V
Terminal	USB2.0
Weight	1.6kg without battery / 1.9kg with battery
Size	143H x 136W x 155D mm (including rubber bumper)

* 1 With identical fibres(in room temperature). Measured by cut-back method relevant to ITU-T and IEC standards.

* 2 0.25mm fiber,may vary depending on the battery status and operating environment.

* 3 Splice & Heat cycles based on 40mm shrink tube.

* 4 Electrode life may vary depending on the operating environment.

Jl. Dukuh Kupang Barat I No.180 Kel. Dukuh Pakis Kec. Dukuh Pakis Surabaya 60225 Jawa Timur - Indonesia

 Falcom Technology

 official.falcomcatv

 Falcom Technology.Official

 www.falcom-technology.com

KL-260T FTTx Fusion Splicer

30 Years of Craftsmanship in Manufacturing
NEW GENERATION
Middle Trunk Line Fusion Splicer

■ Product display



Jl. Dukuh Kupang Barat I No.180 Kel. Dukuh Pakis Kec. Dukuh Pakis Surabaya 60225 Jawa Timur - Indonesia

[Falcom Technology](#) [official.falcomcatv](#) [Falcom Technology.Official](#) [www.falcom-technology.com](#)